

---

## Notes of Attached Figures

**Fig.1 is the overall structure schematic diagram of noncombustible electronic spray cigarette according to the present utility model invention**

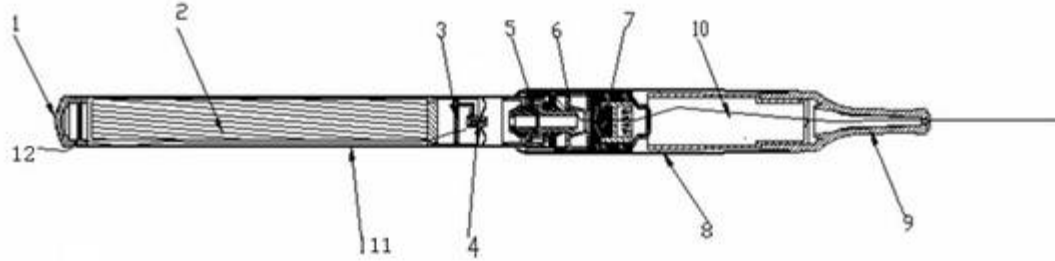

**Fig. 2 is the exploding diagram of noncombustible electronic spray cigarette according to the present utility model invention**

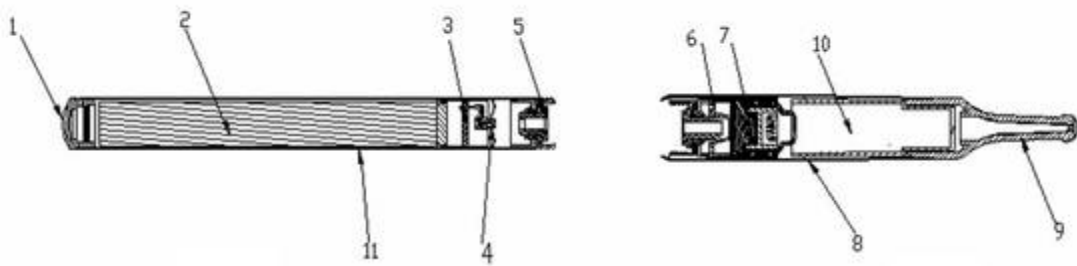

**Fig.3 is the structure schematic diagram of foggy chamber and liquid-guide unit in the noncombustible electronic cigarette according to the present utility model invention**

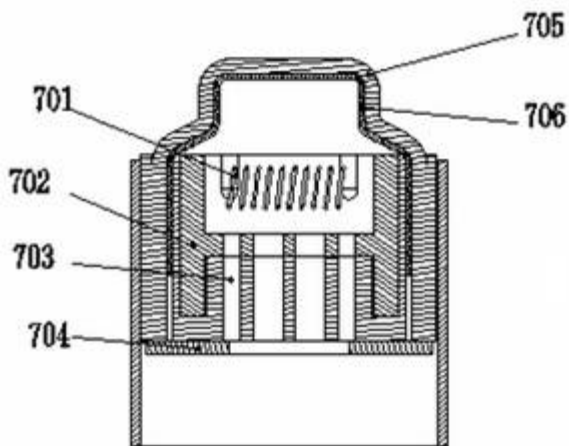

**Fig.4 is the connection structure diagram between the liquid-guide unit and the vaporization chamber/liquid container in the noncombustible electronic spray cigarette according to the present utility model invention**

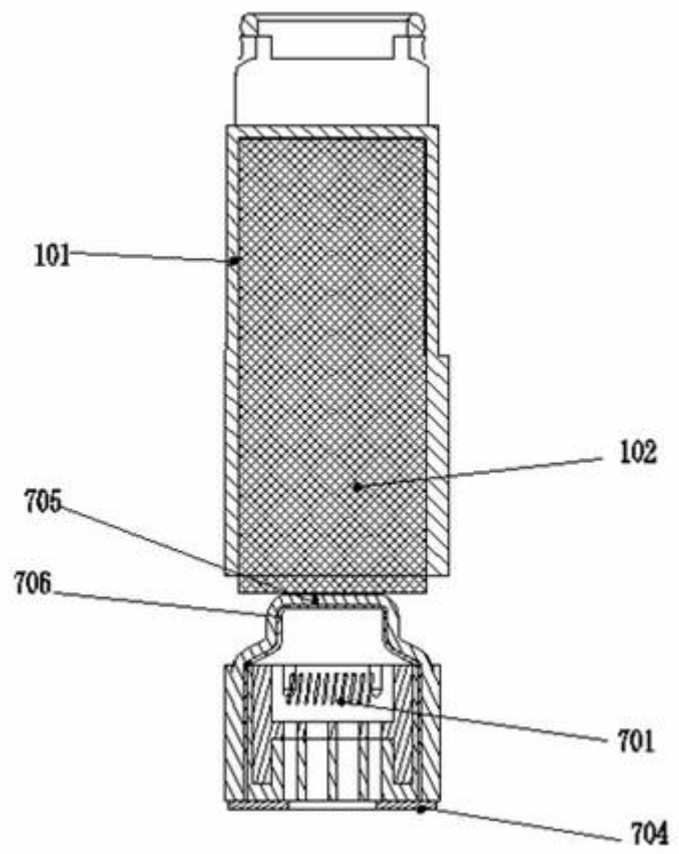

**Fig.5 is the structure schematic diagram of pneumatic switch in the noncombustible electronic spray cigarette according to the present utility model invention**

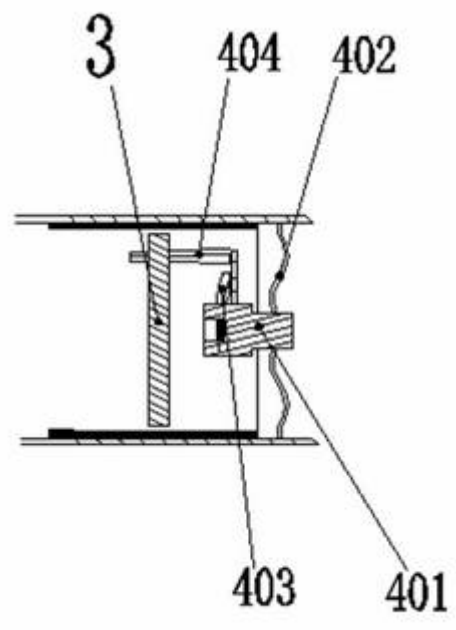

**Fig.6 is the schematic diagram of electric mechanism of the noncombustible electronic spray cigarette according to the present utility model invention**

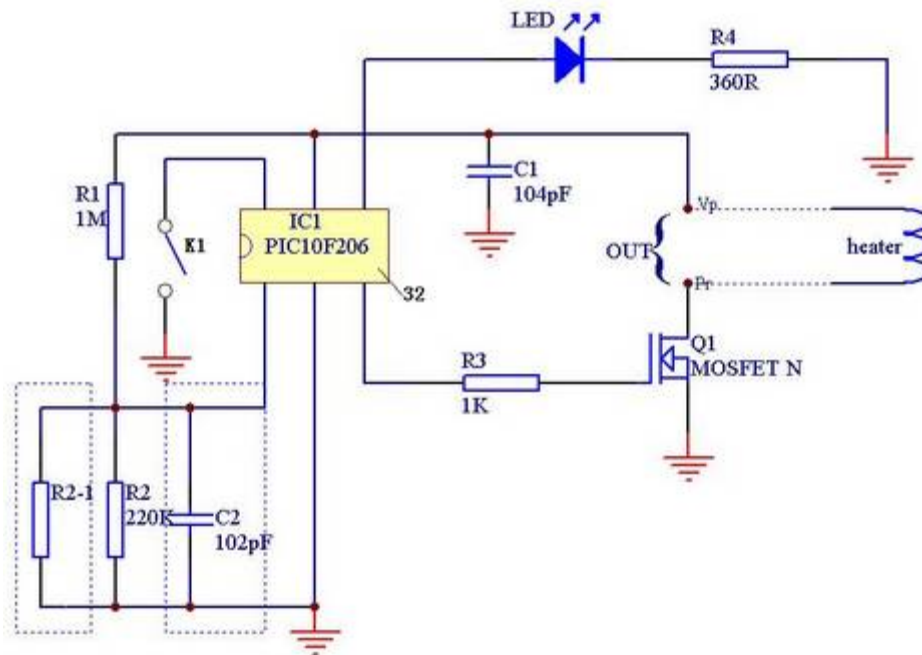

**Fig.7 is the schematic diagram to simulate the amotization and recycling of nicotine solution in the noncombustible electronic spray cigarette according to the present utility model invention**

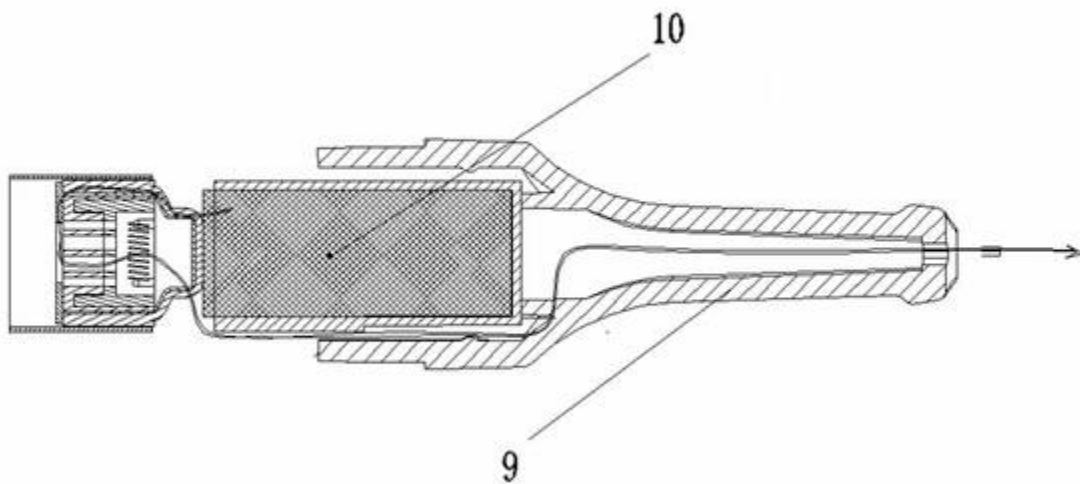

**Details of Invention**

The present invention is a non-combustible electronic spray cigarette consisting of a control unit and an executive unit which are connected with a connector.

Referring to Fig. 1, at one end of the control unit there is a semi-transparent indicator lamp cover 1 on a LED which serves as an indicator lamp. There is a hidden vent hole 12 beside the indicator lamp. At the other end of the control

---

unit there is a connector 5 to connect with the executive unit. A lithium battery 2, a control circuit board 3 and a pneumatic switch 4 are mounted in sequence between indicator lamp cover 1 and the connector 5. The lithium battery 2, control circuit board 3 and pneumatic switch 4 are covered by a control unit shell 11. There is a film inside the pneumatic switch 4 which separates the space between lithium battery 2, control circuit board 3 and connector 5 into two independent cavities. At both ends of the executive unit are the connector 5 and a nozzle 9 respectively. From the connector 5 to nozzle 9, a liquid restrictor 5, a vaporization chamber 7 and a nicotine solution cavity 10 are mounted in sequence. The liquid restrictor 5, vaporization chamber 7 and nicotine solution cavity 10 are covered by an executive unit shell 8 and come with a gas channel at the center.

Further referring to Fig. 2, the lithium battery is an in-built component which can be charged by connecting the connector 5 to a Charger. A non-combustible electronic spray cigarette will be assembled by connecting the control unit to the executive unit.

Referring to Fig. 3, vaporization chamber 7 consists of a heater 701, a connection bracket holder 702, a liquid restrictor 704, a liquid guide unit 705 and a connection bracket 706. The heater 701 is fixed inside vaporization chamber 7. The heater 701 may be made of platinum wires, chrome-nickel alloy wires or aludirome wires containing rare earth element, either in the form of chips or circles. There is an injection hole 703 on the connection bracket holder 702 to connect the vaporization chamber to the outside. Liquid restrictor 704 is made of nylon and other heat-resistant materials for purpose of preventing the back-flow of liquid. There is a vent hole on the liquid restrictor 704 and connection bracket 706. Liquid guide unit 705 is a multi-layer nickel foam web covering the exterior side of connection bracket 706 and connection bracket holder 702.

Further referring to Fig. 4, the liquid guide unit 705 touches liquid restrictor 704 at one end and protrudes to be in contact with porous unit 102 inside the liquid container 101 of nicotine solution cavity 10. The porous unit 102 may be filled with either PP fibers, terylene fibers or nylon fibers. The liquid is led to the cavity between liquid restrictor 704 and connection bracket holder 702 through the liquid guide unit 705 as a result of capillarity. Tiny drops of liquid will be inhaled into the other side of connection bracket holder 702 through the injection hole 703 due to the force of gas flow. The sucked liquid will be

vaporized instantly by the heater 701 and further inhaled out through the vent hole on the exterior of liquid container 101 and the suction nozzle 9. The liquid guide unit 705 may also be made of stainless steel fibrofelt, high polymer foam and ceramic foam.

Referring to Fig. 5, A film 402 inside the pneumatic switch 4 divides the pneumatic switch into two independent cavities. There is a protruding plastic rod 401 attached to the film 402 to connect the film 402 with a copper contact 403. There are two copper brackets 404 on the control circuit assembly 3 facing towards the film. When the operator smokes the cigarette, a negative pressure cavity will be formed on the right side of film 402 due to the action of gas flow and the film 402 will move right due to the action of negative pressure. In this way, copper contact attached to the plastic rod 401 will move right correspondingly, so as to touch the copper bracket 404 on the control circuit assembly 3 and turn on the power; When the operator stop smoking, the film 402 will reset due to its own elastic force. Thus the plastic rod move leftward and the copper contact 403 separates with copper bracket 404. The heater 701 will be powered on/off in this way under the action of small gas flow.

Referring to Fig. 6, gas-flow switch K1, SCM 32. In case of inhalation, gas flow switch K1 closes and SCM 32 will output high level at its pin 3 (GP1) and output extended wave at its pin 4 (GP2) to enable the LED to light up from dark to the brightest; When K opens, pin 3 will output low level and LED dims down. LED will delay for 0.8 second when it dims down or bright up. When K1 has been closed/opened for totally 1500 times, pin 3 will output high level for up to 8 seconds and pin 4 (GP2) will also output high level to light up the LED for 8 seconds. The highest allowed working voltage for SCM 32 in this invention is 4.2 V and the lowest voltage is 3.5 V. The preferred working voltage is 4.0 V. In case of low voltage less than 3.5 V, pin 4 (GP2) of the SCM will output a pulse wave of 2 Hz to enable the LED to flicker, indicating the battery is short of power. The pulse wave will last for 20 seconds. In the course of low-power indicating, pin 3 (GP1) will output low level.

The SCM 32 features counting memory function and low voltage alert function. In case the operator operates over-frequently, it can cut off the power automatically to prevent abuse of this Cigarette. When the switch has been on/off for over 1500 times, an instruction will be given by the SCM to allow automatic cleaning of atomization head for six seconds; In case of extra-low voltage, the

---

**indicator lamp will flicker continually for 20 seconds to warn extra-low voltage. Customized programs may be input to the SCM for more functions or further upgrading. SCM is the key to control the work of electronic cigarette but not the source of health-friendliness of the electronic cigarette. The gas amount of smoking depends on the amount of breathing of the smoker. The electronic cigarette uses nicotine solution which is an extra-pure alkaloid without producing any carbon monoxide or tar.**

In this example, the non-combustible electronic spray cigarette works in the following procedures: The control unit and executive unit are combined through the connector 5 into a non-combustible electronic spray cigarette; When the user inhales it, a gas flow enters the executive unit through the vent hole, and pass through liquid restrictor 6, vaporization chamber 7 and nicotine solution cavity 10 before finally leaving the cigarette through the nozzle 9. There is a through hole inside the connector 5. When the operator inhales, the gas flow in the executive unit will go towards the nozzle and produce a subatmospheric cavity in the control unit near the connector 5 while the cavity at the other end of the control unit near the battery maintains normal atmospheric pressure due to the vent hole 12. Thus, due to the action of negative air pressure, the switch stretches towards the connector 5 and moves the copper contactor 403 to turn on the power. Now the indicator lamp will light on gradually under the control of relay circuit and the current reaches the vaporization chamber 7 through connector 5 and liquid restrictor 6. The solution will be injected into the vaporization chamber 7 in the form of tiny droplets with the help of gas flow and atomized instantly by the heater. Those large droplets will be re-absorbed by the liquid guide unit through over-flow holes after they are attached to the walls due to vortex action. Small droplets will be turned into aerosol and inhaled out through the nozzle